

TX-KFP

Diffusion type gas detector for gas cabinet & scrubber applications

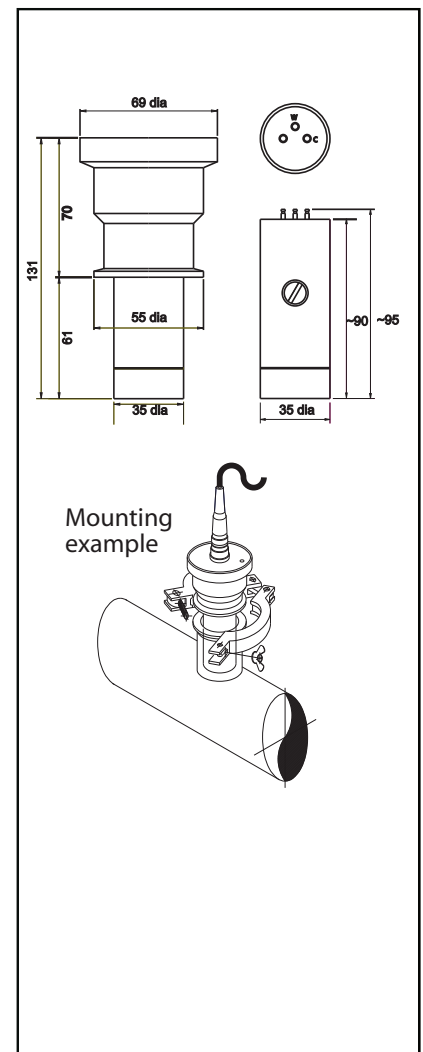

Part #	10543	11099	11093
Model	TX-[]KFP	Junction box	conn. cable 2,5 m
Gas Sensor type	GS- []DP/ GS- []ELP		
Target gas	Please refer to the gas list		
Monitoring configuration	Single point, diffusion		
Detection principle	Electrochemical		
Output signal	4 - 20 mA, 2 wired		
Accuracy	± 5% ¹⁾		
Indicator	Optional external analog or digital indicator. Information on the indicators can be found in the accessories section		
Operation temperature	-10° to +40°C		
Operating humidity	5 - 95 % (non condensing)		
Installation	Indoor, NW-40 flange- or wall mount. Information on the available mounting materials can be found in the accessories section		
Flange connection	KF-40		
Cable connection	KGV-60 female connector (SV-60 male connector is included)		
Material body	Stainless Steel		
Power requirements	24 Volt DC		
Power consumption (max.)	1.2 Watt		
Dimensions (approx.)	(H x diam.) 131x Ø69 mm		
Weight (approx.)	0,5 kg		
Country of origin	Netherlands		



1) Accuracy is subject to the calibration mixture.